

REDUTORES DE VELOCIDADE A ROSCA SEM FIM - LINHA R FERRO FUNDIDO

DIMENSÕES (mm)

EIXO SAÍDA MACIÇO

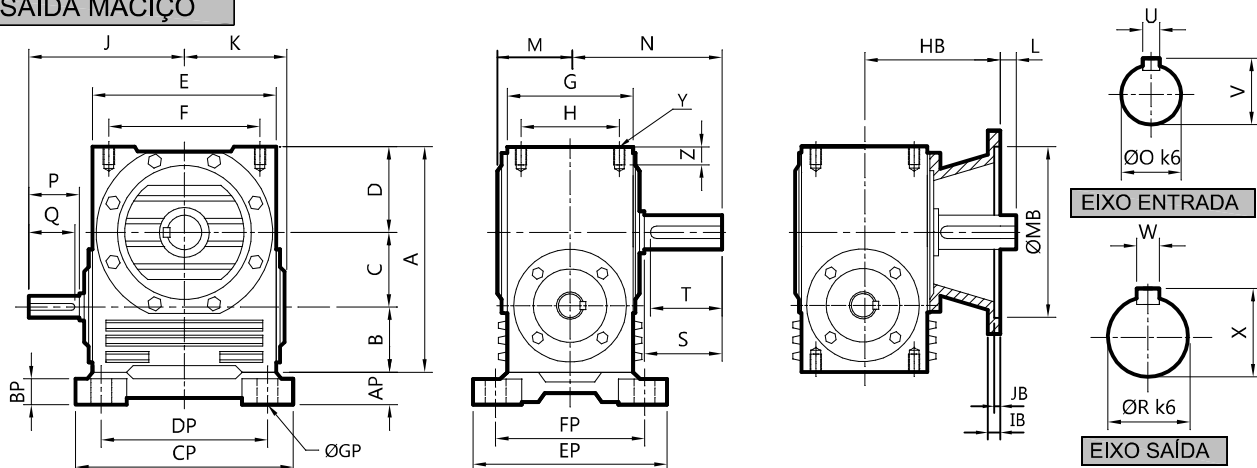

EIXO SAÍDA VAZADO

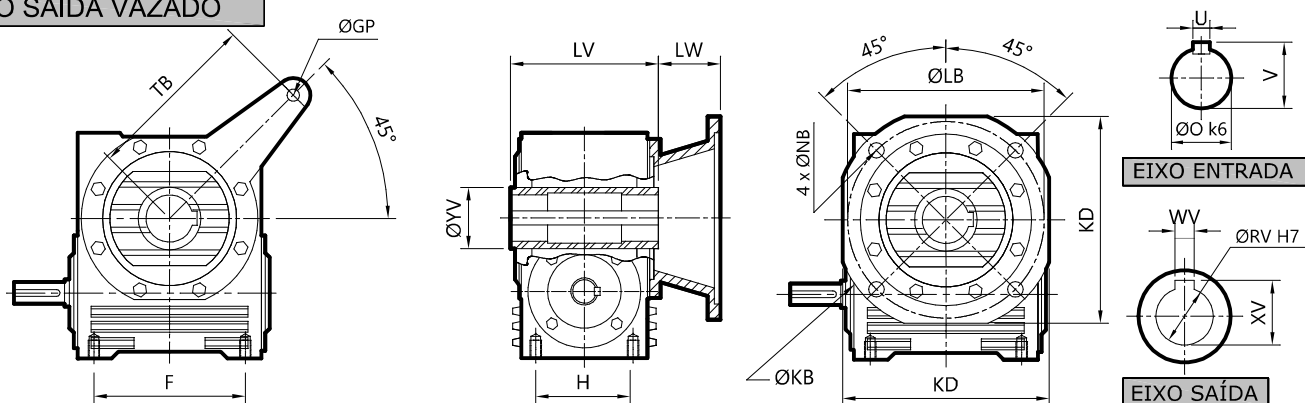

COM PÉS FIXOS *

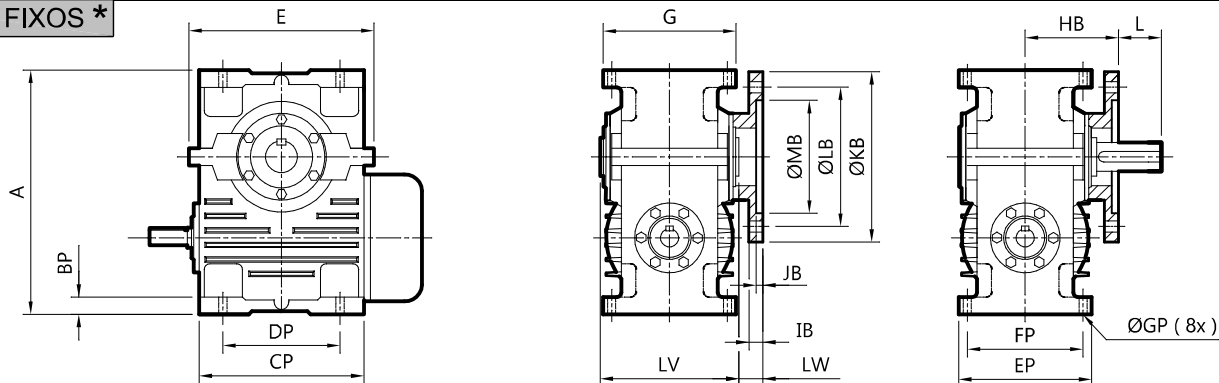

*SOMENTE PARA OS TAMANHOS R10, R11 E R12

TIPO	A	B	C	D	E	F	G	H	J	K	L	M	N	ØO	P	Q	ØR	S	T	U	V	W	X
R7	302	72	110	120	232	195	124	88	198	132	32	84	185	32	60	57	45	95	92	10	35,0	14	48,5
R8	358	81	135	142	282	236	134	98	234	158	30	90	200	38	70	67	55	105	102	10	41,0	16	59,0
R9	440	100	165	175	330	273	154	110	267	185	31	99	212	45	80	77	60	110	107	14	48,5	18	64,0
R10	560	120	200	240	444	—	270	—	347	349	80	144	310	60	100	95	80	160	150	18	64,0	22	85,0
R11	666	178	240	248	533	—	340	—	412	375	131	176	363	70	140	130	90	180	170	20	74,5	25	95,4
R12	835	255	280	300	640	—	460	—	485	483	156	229	439	80	160	150	110	200	190	22	85,0	28	116,0

TIPO	Y	Z	AP	BP	CP	DP	EP	FP	ØGP	HB	IB	JB	ØKB	KD	ØLB	ØMB	ØNB	ØRV	ØVV	WV	XV	LV	LW	TB
R7	M16	28	30	22	260	222	201	166	17	153	14	5	304	255	274	244	13	45	65	14	48,8	166	70,5	250
R8	M16	28	33	23	303	266	212	176	17	171	15	5	374	309	334	295	16	50	70	14	53,8	180	81,0	300
R9	M18	30	36	28	366	309	240	199	20	181	17	5	444	360	392	340	20	55	80	16	59,3	204	79,0	355
R10	—	—	—	40	444	340	270	222	27	230	17	5	444	360	392	340	20	90	130	25	95,4	300	80,0	—
R11	—	—	—	45	474	346	340	270	28	232	20	7	470	—	410	360	26	100	140	28	106,4	366	49,0	—
R12	—	—	—	60	566	420	460	400	32	283	20	7	470	—	410	360	26	110	150	28	116,4	476	49,0	—